

The FOM-Institute for Plasma Physics Rijnhuizen

Introduction

Aart Kleyn

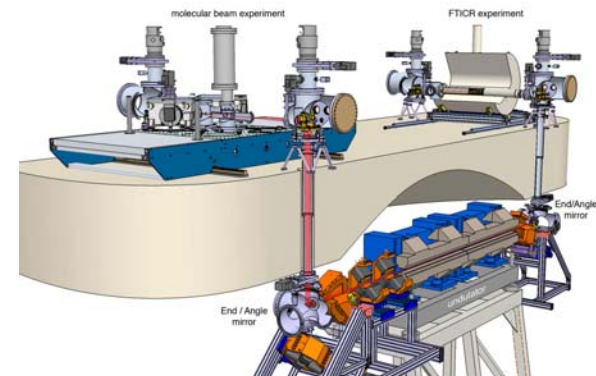
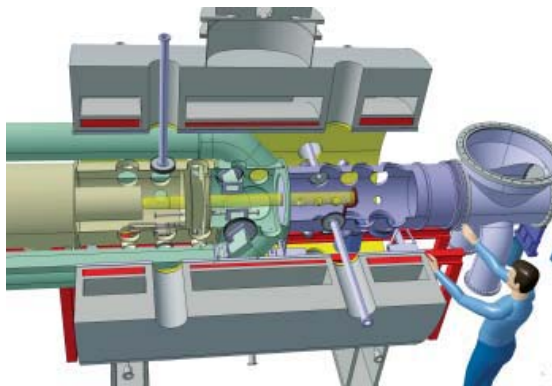

- 1959: Founded for Fusion
- 1986: Quantum electronics (FELIX) added to mission
- 2007: nanolayer Surface and Interface Physics division created

Institute's mission
contains three parts



Figure 1.
The front entrance of FOM-Rijnhuizen.

Mission:

- To perform high-quality scientific research and to develop methods and techniques with that aim, in the field of:
 - Fusion physics (46 fte)
 - Generation and Utilization of THz radiation (GUTHz) (16 fte)
 - nanolayer Surface and Interface Physics (nSI) (25 fte)
- To train graduate and undergraduate students and technicians
- To transfer high-level scientific and technical knowledge to society at large.

Objectives

Scientific research on fusion energy, oriented at ITER.

Highlights 2002-2007

- Control of tearing modes with Electron Cyclotron Waves in TEXTOR
- ITER-divertor grade plasma generation in Pilot-PSI; Magnum-PSI
- World-leading advanced diagnostic: Charge-Exchange Recombination spectroscopy (CXRS), Imaging Electron Cyclotron Emission spectroscopy, Thomson scattering
- Broadening of the Dutch Fusion program to TNO and industry, resulting in the ITER-NL consortium.
- Positioning of fusion as a sustainable energy source in Dutch political bodies and ministries. Fusion research priority area in FOM.

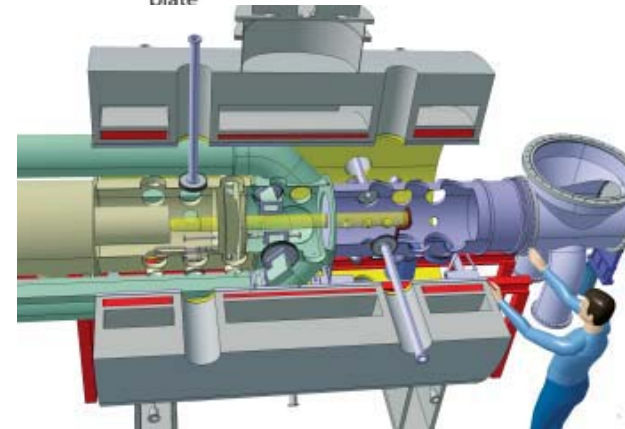
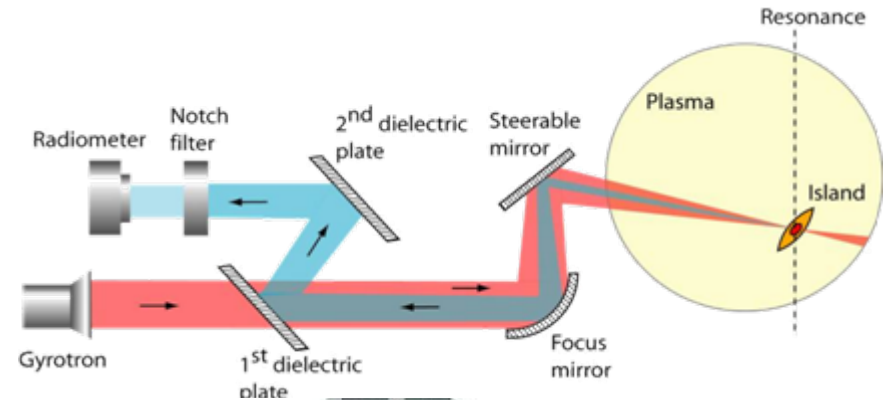

Objectives

- to operate the IR user facility FELIX
- to run an in-house program in the field of molecular dynamics and THz spectroscopy
- to design and construct FELICE, a new beamline for intra-cavity experiments

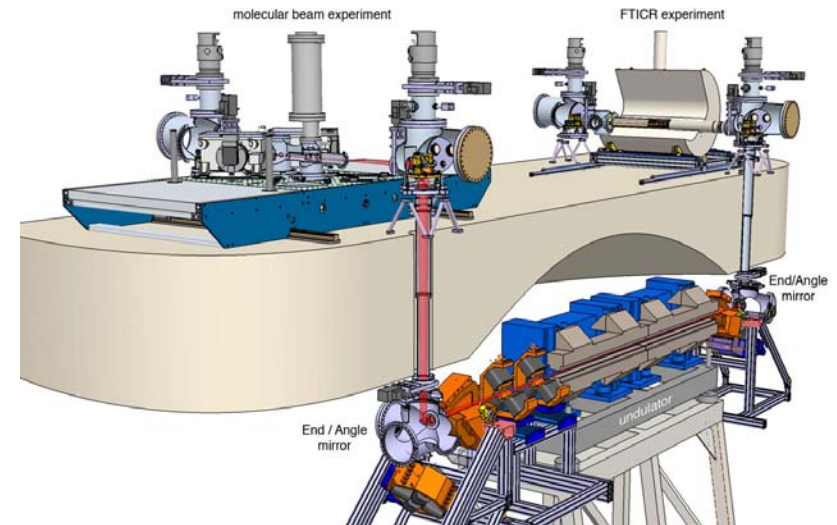

Objectives

Physics & technology of thin film, multilayer and surface systems, for XUV optical and plasma physics

Highlights 2002 – 2007

- Holder of world records on optics performance due to atomic-scale control of layer growth (patented methods)
- Basic & applied physics research with 8 PhD theses and 20 patents ('02-'07), 8 pending
- Development of unique deposition and analysis infrastructure, leading to **transfer of know-how** to industry (Carl Zeiss SMT, ASML, Philips).

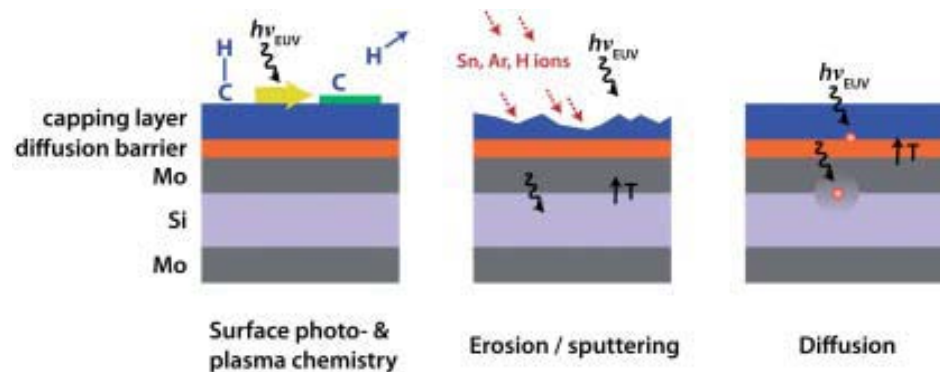

- Samsung corporation:

fusion technology =
Information technology +
nano technology +
bio technology

- All are present at Rijnhuizen

Running budget - 2002-2007

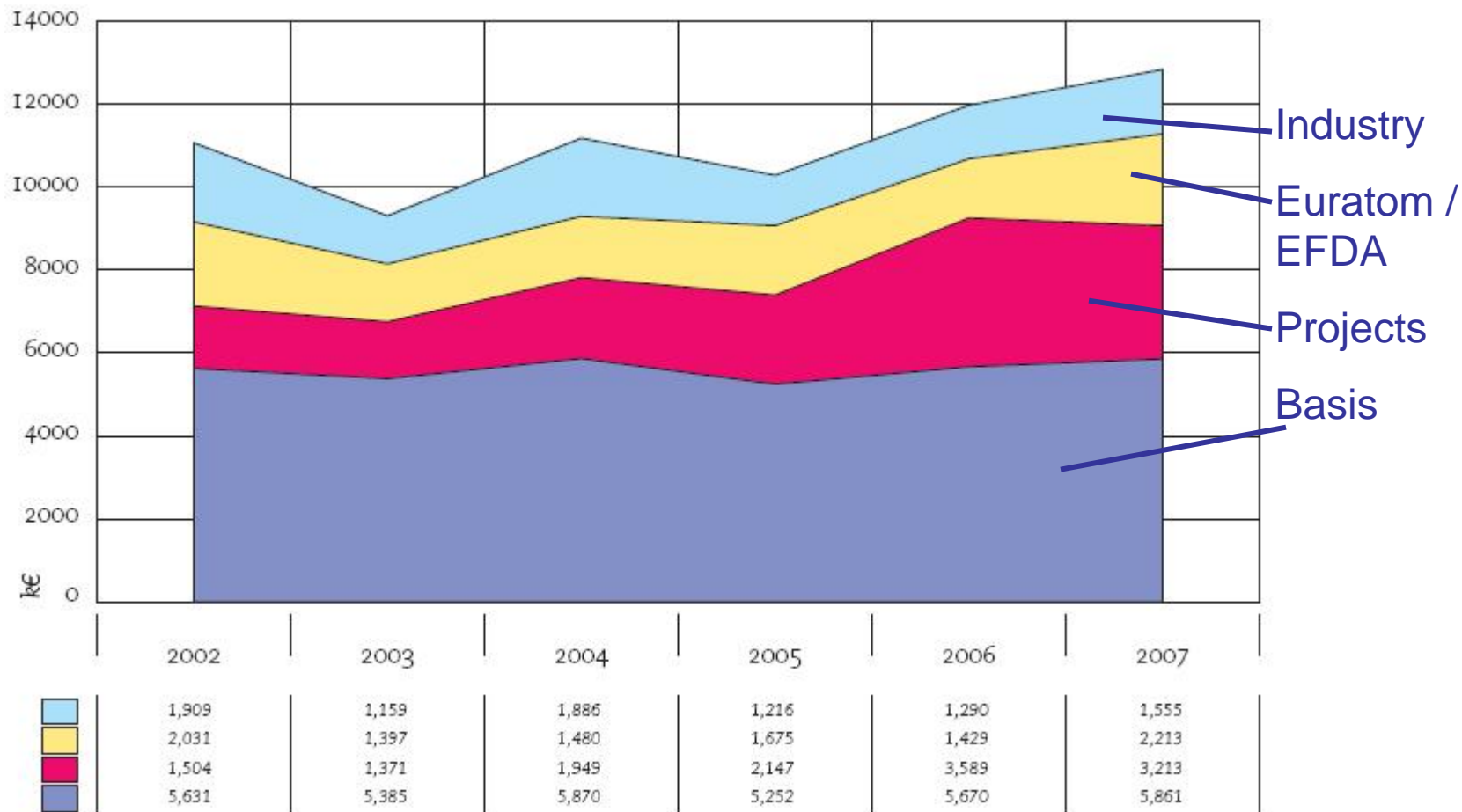

Employees in 2007

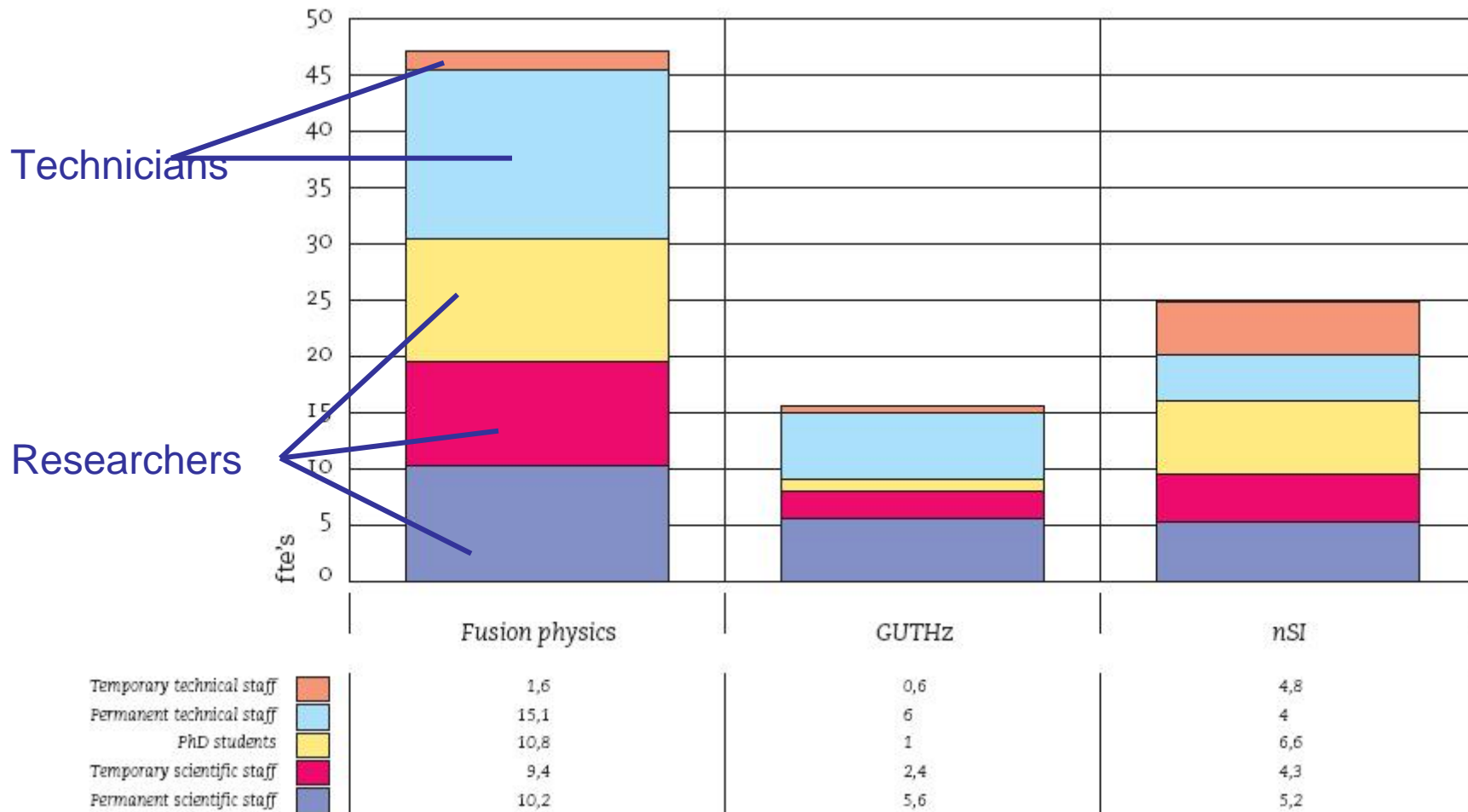

Figures of merit



Parameter	unit	2002	2003	2004	2005	2006	2007	average
Base support NWO/FOM	k€	5631	5385	5870	5252	5670	5861	5612
Third parties (including EU), contracts, special funds etc.	k€	5444	3927	5315	5038	6308	6981	5502
	(%)	49	42	48	49	53	54	50
Total	k€	11075	9312	11185	10290	11978	12842	11114
Ratio third parties/ base support		1,0	0,7	0,9	1,0	1,1	1,2	1,0
Investment budget	k€	1012	5333	4706	701	7108	5258	4629
Ratio investment/exploitation		0,09	0,57	0,42	0,07	0,59	0,41	0,36
Total scientific staff fte		54	59	50	52	49	54	53
Ratio temporary/permanent scientific staff		2,6	2,3	2,1	1,3	1,2	1,6	1,9
Support staff (technical and general)	fte	75	83	76	81	85	87	81
Ratio support staff/scientific staff		1,4	1,4	1,5	1,6	1,7	1,6	1,5
Personnel costs/exploitation costs		0,65	0,82	0,7	0,75	0,66	0,66	0,71
Exploitation costs/scientific staff	k€/fte	205	158	224	198	244	238	211
Refereed journal publications		118	128	132	113	105	97	116
Ratio publications/scientific staff		2,2	2,2	2,6	2,2	2,1	1,8	2,2
PhD theses		3	4	7	4	7	7	5,3
Patents		6	4	6	1	3	3	3,8